

**Gympie Regional Council**

24 Mellor Street, PO Box 155, Gympie QLD 4570
 Telephone 1300 307 800 Facsimile 07 5481 0801
 Email council@gympie.qld.gov.au
 Website www.gympie.qld.gov.au

Portable Lifting Platform Hire Application Form

Applicants Details

PRIVACY STATEMENT: Gympie Regional Council collects personal information where it is directly related to a function or activity of Council and where the collection of such information may be reasonably considered as necessary for that purpose. It will only use personal information for that purpose, and will not disclose it, except as permitted under the Information Privacy Act 2009.

Name of Applicant (in full)
(Surname) (Given Names)

Name of Non-Profit Organisation

Postal Address

Phone Number
(Home) (Work) (Mobile)

I hereby declare that the information I have provided herein is true and correct to the best of my knowledge and I have read and accept the Portable Lifting Platform conditions of hire.

Signature Date / / 20

Location of Use

Name of Location where Lift is to be used *Eg Hall*

Street address of hire location

Date of intended use / / 20 to / / 20

Collection time (from Civic Centre) : am / pm / / 20

Return time (return to Civic Centre) : am / pm / / 20

Notes:

Signature

I have read the Conditions of Hire, and understand fully the Instructions provided on this form.

Name

Signature and date / / 20

Fees

Payments may be made by cheque or money order. Payments made in person must be lodged with Council's Finance Directorate at the Gympie Town Hall, 2 Caledonian Hill, Gympie (near the Five-ways Roundabout) or Kilkivan Branch, 26 Bligh Street, Kilkivan

Total Fees Paid \$ Date / / 20.....

Ledger No. (Bond) T188 GL:4810150.2000 Receipt No.
 No GST

CONDITIONS OF HIRE

- It shall be at the discretion of the Regional Council to refuse to hire the Portable Lifting Platform out in any case and notwithstanding that the Portable Lifting Platform may have been let or that these conditions may have been accepted and signed and the rent paid, the Council shall have full power, if it sees fit, to cancel such hiring and direct the return of the hire fees and deposit so paid and the hirer hereby agrees to accept the same and to be held to have consented to such cancellation and to have no claim at law or in equity for any loss or damage in consequence thereof.
- The hirer shall be responsible for any damage caused to the Portable Lifting Platform during the hire period.
- All hirers shall lodge a security deposit of an amount set by Council prior to their collection of the Portable Lifting Platform. Such bond shall be refundable only after satisfactory inspection of the equipment.
- The Portable Lifting Platform must only be used by persons in a wheelchair, and only the approved Applicant nominated on this form may operate the device.
- The Portable Lifting Device may only be operated in the location nominated on this application form.
- If the hirer fails to make the bond payment by the time required, the Council may cancel the booking of the Portable Lifting Platform

INSTRUCTIONS FOR USE

The Portable Lifting Platform is an ideal solution for where wheelchair access is required to stages or mezzanine levels in halls, theatres etc.

The self-contained unit can be rolled into position on its caster wheels, and plugs into an existing power point, or for short periods of use, can run on the internal battery for up to 30 cycles.

Folded Dimensions (in mm)

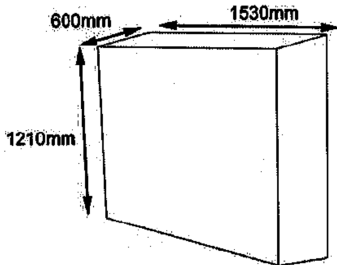

Portable Lifting Platform Dimensions (in mm)

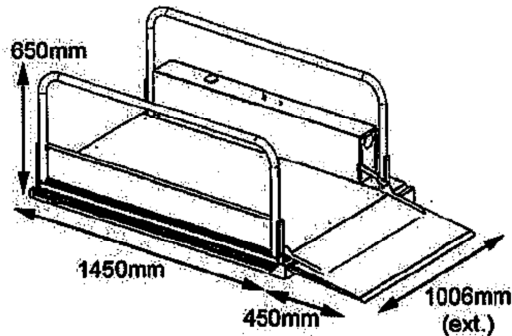

Installation Notes



Step 1
Wheel lift to required location.
NOTE: 2 person operation.

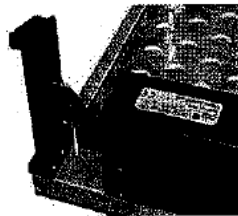

Step 5
Remove transit locking bolt holding ramp down on platform & place into holder

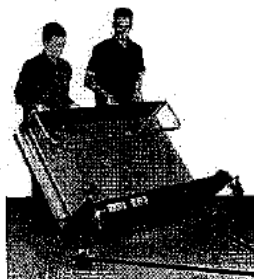

Step 2
Ensure wheels are locked. Lower platform on to base & slide into required position.

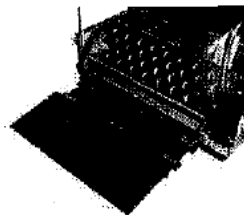

Step 6
Place ramp in position



Step 3
Remove large castors



NOTE
While lift is in storage / operation ensure the charger is plugged into charging socket and that the battery isolator is off.



Step 4
Position handrail uprights and secure using wing nuts.

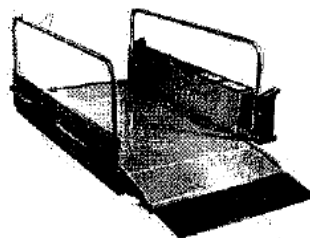

To fold down the lift, follow the above steps exactly in reverse. Do not forget to make sure the wheels are still locked when lifting the device into the upright position for transportation.

NOTE: Ensure that two strong adults are available to lift the portable lift into the upright position for transport, or to lower the lift to the ground for assembly. The lift is very heavy.